

# ON THE SHAPE OF THE SYMMETRIC, PERSYMMETRIC AND SKEW-SYMMETRIC SOLUTION SET

GÖTZ ALEFELD\*, VLADIK KREINOVICH†, AND GÜNTER MAYER‡

**Abstract.** We present a characterization of the solution set  $S$ , the symmetric solution set  $S_{sym}$ , the persymmetric solution set  $S_{per}$  and the skew-symmetric solution set  $S_{skew}$  of real linear systems  $Ax = b$  with the  $n \times n$  coefficient matrix  $A$  varying between a lower bound  $\underline{A}$  and an upper bound  $\overline{A}$ , and with  $b$  similarly varying between  $\underline{b}$ ,  $\overline{b}$ . We show that in each orthant the sets  $S_{sym}$ ,  $S_{per}$  and  $S_{skew}$ , respectively, are the intersection of  $S$  with sets the boundaries of which are quadrics.

**Key words.** linear systems with perturbed input data, solutionset of linear systems of equations, symmetric matrices, persymmetric matrices, skew-symmetric matrices, Oettli-Prager Theorem, Fourier-Motzkin elimination, interval analysis.

**AMS subject classifications.** 65G10, 65F05

*Dedicated to Prof. Dr. Gerhard Maeß, Rostock, on the occasion of his 60<sup>th</sup> birthday.*

**1. Introduction.** Let  $[A]$  be an  $n \times n$  matrix with compact intervals as entries, let  $[b]$  be a vector with  $n$  interval components and let  $E$  be the  $n \times n$  permutation matrix with ones in the northeast-southwest diagonal and zeros elsewhere. The purpose of this paper consists in characterizing the solution sets

$$\begin{aligned}
 (1.1) \quad S &:= \{x \in \mathbf{R}^n \mid Ax = b, A \in [A], b \in [b]\}, \\
 (1.2) \quad S_{sym} &:= \{x \in \mathbf{R}^n \mid Ax = b, A = A^T \in [A] = [A]^T, b \in [b]\}, \\
 (1.3) \quad S_{per} &:= \{x \in \mathbf{R}^n \mid Ax = b, EA = (EA)^T \in E[A] = (E[A])^T, b \in [b]\}, \\
 (1.4) \quad S_{skew} &:= \{x \in \mathbf{R}^n \mid Ax = b, A = -A^T \in [A] = ([a]_{ij}) = -[A]^T, \\
 &\quad [a]_{ii} = 0 \text{ for } i = 1, \dots, n, b \in [b]\}
 \end{aligned}$$

by means of inequalities which show that in each fixed orthant  $O$  the solution set  $S$  is the intersection of finitely many half spaces, while  $S_{sym} \cap O$ ,  $S_{per} \cap O$  and  $S_{skew} \cap O$  is the intersection of  $S \cap O$  with finitely many sets, the boundaries of which are conic sections in  $\mathbf{R}^n$ . The characterization of  $S \cap O$  was already given in [4], [5], [7], [11], [12] and others while the characterization of  $S_{sym} \cap O$  in the two dimensional case was derived in [4]. The technique there could not be transferred onto the general case in an obvious way. We will use here a different technique known as Fourier-Motzkin elimination which is described, e. g., in [14].

Note that we require

$$(1.5) \quad \left\{ \begin{array}{l} \text{no additional condition on } [A] \text{ in the case of } S, \\ [A] = [A]^T \text{ in the case of } S_{sym}, \\ E[A] = (E[A])^T \text{ in the case of } S_{per}, \\ [A] = ([a]_{ij}) = -[A]^T \text{ with } [a]_{ii} = 0, i = 1, \dots, n, \text{ in the case of } S_{skew}. \end{array} \right.$$

The restrictions in (1.5) are not severe. If  $[A] \neq [A]^T$  in the case of  $S_{sym}$ , e. g., and if  $[B]$  denotes the largest interval matrix in  $[A]$  such that  $[B] = [B]^T$  holds then the

---

\* Institut für Angewandte Mathematik, Universität Karlsruhe, D-76128 Karlsruhe, Germany ([goetz.alefeld@mathematik.uni-karlsruhe.de](mailto:goetz.alefeld@mathematik.uni-karlsruhe.de)).

† Department of Computer Science, University of Texas at El Paso, El Paso, TX 79968, USA ([vladik@cs.utep.edu](mailto:vladik@cs.utep.edu)).

‡ Fachbereich Mathematik, Universität Rostock, D-18051 Rostock, Germany ([guenter.mayer@mathematik.uni-rostock.de](mailto:guenter.mayer@mathematik.uni-rostock.de)).

matrices in  $[A] \setminus [B]$  do not influence  $S_{sym}$ . Therefore, instead of  $[A]$  the matrix  $[B]$  would play the crucial role in characterizing  $S_{sym}$ .

We emphasize that  $[A]$  is allowed to contain singular real matrices. The restriction  $[a]_{ii} = 0$ ,  $i = 1, \dots, n$  in the case of  $S_{skew}$  stems from the fact that a skew-symmetric matrix  $A = (a_{ij}) \in \mathbf{R}^{n \times n}$  is defined by  $A = -A^T$  which implies  $a_{ii} = 0$  for  $i = 1, \dots, n$ . We also recall that this matrix is singular if  $n$  is odd. This can be seen from  $\det A = \det(-A^T) = \det(-A) = (-1)^n \det A$ . The condition  $EA = (EA)^T$  for  $S_{per}$  characterizes a persymmetric matrix which is defined to be symmetric with respect to the northeast-southwest diagonal; cf. [6], e. g.

The sets in (1.1) – (1.4) occur when dealing with linear systems of equations the input data of which are afflicted with tolerances (cf. [1], [10] or [13], e. g.). This is the case when data  $\check{A}$ ,  $\check{b}$  are perturbed by errors caused, e. g., by measurements or by a conversion from decimal to binary digits on a computer. Assume that these errors are known to be bounded by some quantities  $\Delta A \in \mathbf{R}^{n \times n}$  and  $\Delta b \in \mathbf{R}^n$  with nonnegative entries. Then it seems reasonable to accept a vector  $\tilde{x}$  as the ‘correct’ solution of  $\check{A}x = \check{b}$  if it is in fact the solution of a perturbed system  $\check{A}x = \check{b}$  with

$$\check{A} \in [A] := [\check{A} - \Delta A, \check{A} + \Delta A], \quad \check{b} \in [b] := [\check{b} - \Delta b, \check{b} + \Delta b].$$

The characterization of all such  $\tilde{x}$  led Oettli and Prager [11] to their famous equivalence

$$(1.6) \quad x \in S \iff |\check{b} - \check{A}x| \leq \Delta A|x| + \Delta b$$

where  $|v| := (|v_i|) \in \mathbf{R}^n$  for  $v = (v_i) \in \mathbf{R}^n$ . It relates the midpoint residual to the tolerances and to  $|x|$  and was reformulated in [7] similarly as in the subsequent Theorem 3.4. Often  $\check{A}$  belongs to a particular class of matrices with dependencies in their entries. Such a class is formed by symmetric matrices, persymmetric matrices, skew-symmetric matrices, and others, respectively. Therefore it is reasonable to consider subsets of  $S$  for which the elements  $x$  are solutions of linear systems  $Ax = b$  with *special* matrices  $A$  only. This leads to the problem discussed in the present paper. Our results are formulated in terms of inequalities involving the bounds of  $[A]$ ,  $[b]$ . They can easily be reformulated using the midpoints  $\check{A}$ ,  $\check{b}$  and the tolerances  $\Delta A$ ,  $\Delta b$  although a compact form such as (1.6) is still missing.

We also mention that the sets  $S_{sym}$  and  $S_{skew}$  already have been considered in [8] and [9]. There, bounds for the projections of these sets onto the coordinate axes have been derived but no characterization of these sets have been given.

We have arranged our paper as follows: In Section 2 we list the notation which we will use throughout the paper, in Section 3 we present the results. We close our paper with some examples in Section 4 which illustrate the technique and the theory.

**2. Preliminaries.** By  $\mathbf{R}^n$ ,  $\mathbf{R}^{n \times n}$ ,  $\mathbf{IR}$ ,  $\mathbf{IR}^n$ ,  $\mathbf{IR}^{n \times n}$  we denote the set of real vectors with  $n$  components, the set of real  $n \times n$  matrices, the set of intervals, the set of interval vectors with  $n$  components and the set of  $n \times n$  interval matrices, respectively. By ‘interval’ we always mean a real compact interval. Interval vectors and interval matrices are vectors and matrices, respectively, with interval entries. We write intervals in brackets with the exception of degenerate intervals (so-called *point intervals*) which we identify with the element being contained, and we proceed similarly with interval vectors and interval matrices. We write  $[A] = [\underline{A}, \overline{A}] = ([a]_{ij}) = ([\underline{a}_{ij}, \overline{a}_{ij}]) \in \mathbf{IR}^{n \times n}$  simultaneously, without further reference, and we use an analogous notation for intervals and interval vectors. By  $[A]^T$

we mean the transposed matrix of  $[A]$ . We mention that  $[A] = [A]^T$  is equivalent to  $\underline{A} = \underline{A}^T$  and  $\overline{A} = \overline{A}^T$ , and that  $[A] = -[A]^T$  is equivalent to  $\underline{A} = -\overline{A}^T$  and  $\overline{A} = -\underline{A}^T$ . Therefore, if an interval matrix  $[A]$  fulfills the condition  $[A] = -[A]^T$ , its midpoint matrix  $\check{A} := \frac{1}{2}(\underline{A} + \overline{A})$  satisfies  $\check{A} = -\check{A}^T$ , i. e.,  $\check{A}$  is skew-symmetric. We call an  $n \times n$  interval matrix *singular* if it contains at least one singular real matrix, otherwise we call it *regular*. For computations with interval quantities we refer to [1] or [10].

By  $O$  we denote any closed orthant of  $\mathbf{R}^n$ . In order to distinguish between the sets  $S$ ,  $S_{sym}$ ,  $S_{per}$  and  $S_{skew}$  we call  $S_{sym}$  the *symmetric solution set*,  $S_{per}$  the *persymmetric solution set* and  $S_{skew}$  the *skew-symmetric solution set*.

**3. Results.** We start this section with a topological result which for  $S$  and  $S_{sym}$  is already known (see [4]).

**THEOREM 3.1.** *Let  $[A] \in \mathbf{IR}^{n \times n}$  be regular and satisfy (1.5).*

a) *Each of the sets  $S_{sym}$ ,  $S_{per}$ ,  $S_{skew}$ ,  $S \cap O$ ,  $S_{sym} \cap O$ ,  $S_{per} \cap O$ ,  $S_{skew} \cap O$  is compact.*

b) *Each of the sets  $S$ ,  $S_{sym}$ ,  $S_{per}$ ,  $S_{skew}$ ,  $S \cap O$  is connected;  $S \cap O$  is convex.*

*Proof.* First, we prove the assertions for  $S_{skew}$ . Let  $A = -A^T \in [A]$  and interpret  $x = A^{-1}b$  as a function  $f$  of the  $\frac{n(n-1)}{2}$  variables  $a_{ij}$ ,  $1 \leq i < j \leq n$ , and the  $n$  variables  $b_i$ ,  $1 \leq i \leq n$ . This function is continuous. Since  $[a]_{ij}$ ,  $[b]_i$  are connected and compact the same holds for the range  $S_{skew}$  of  $f$ .

The compactness of the intersection  $S_{skew} \cap O$  follows from  $S_{skew}$  being compact and from  $O$  being closed.

In the cases of  $S$ ,  $S_{sym}$  and  $S_{per}$  one proves the assertions by similar arguments.

The convexity of  $S \cap O$  results from the fact that this set can be expressed as the intersection of finitely many half spaces (cf. [11] or the subsequent Theorem 3.4, for example).  $\square$

**REMARK.** If  $[A]$  is singular but contains no singular *symmetric* matrix the proof of Theorem 3.1 shows that  $S_{sym}$  remains compact and connected and that  $S_{sym} \cap O$  remains compact. An analogous statement holds for  $S_{per}$ ,  $S_{skew}$ ,  $S_{per} \cap O$ , and  $S_{skew} \cap O$ , respectively. For singular  $[A]$  the solution set  $S$ , however, is empty or unbounded since the kernel of each singular matrix  $A \in [A]$  is unbounded. Due to singularity, the function  $f$  with  $f(A, b) := A^{-1}b$  is certainly not defined on  $[A] \times [b]$ . This already indicates that the assertions of Theorem 3.1 may be wrong in the singular case. As an illustration we consider the example

$$[A] := \begin{pmatrix} 0 & [-1, 1] \\ [-1, 1] & 0 \end{pmatrix}, \quad [b] := \begin{pmatrix} 1 \\ 0 \end{pmatrix}.$$

Any real matrix  $A \in [A]$  can be represented by

$$A = \begin{pmatrix} 0 & \alpha \\ \beta & 0 \end{pmatrix}$$

with  $\alpha, \beta \in [-1, 1]$ . Hence  $A$  is regular with

$$A^{-1} = \begin{pmatrix} 0 & \beta^{-1} \\ \alpha^{-1} & 0 \end{pmatrix}$$

provided that  $\alpha\beta \neq 0$ . We obtain

$$\begin{aligned} S &= \{(\gamma, \delta)^T \mid \gamma \in \mathbf{R}, -\infty < \delta \leq -1 \text{ or } 1 \leq \delta < \infty\}, \\ S_{sym} = S_{skew} &= \{(0, \delta)^T \mid -\infty < \delta \leq -1 \text{ or } 1 \leq \delta < \infty\}, \end{aligned}$$

which shows that neither  $S$  nor  $S_{sym}$  nor  $S_{skew}$  is compact or connected in this case.  $\square$

Our next theorem characterizes  $S_{skew}$  by a set of inequalities. Its proof starts with

$$(3.1) \quad x \in S_{skew} \iff \underline{b} \leq Ax \leq \bar{b}, \quad A = -A^T \in [A],$$

transforms the inequalities in a suitable way by introducing new variables  $z_{ij}$  and continues by applying the Fourier–Motzkin elimination (see [14], e.g.) in order to replace the entries of  $A$  by their bounds  $\underline{a}_{ij}$  and  $\bar{a}_{ij}$ , respectively.

**THEOREM 3.2.** *Let  $[A] = -[A]^T \in \mathbf{IR}^{n \times n}$  with  $[a]_{ii} = 0$ ,  $i = 1, \dots, n$ , and let  $[b] \in \mathbf{IR}^n$ . Then for any orthant  $O \subseteq \mathbf{R}^n$  the set  $S_{skew} \cap O$  can be represented as an intersection of finitely many closed sets the boundaries of which are quadrics or hyperplanes. The inequalities characterizing these hyperplanes and quadrics can be derived from  $\underline{b} \leq Ax \leq \bar{b}$ ,  $A = -A^T \in [A]$ ,  $x \in O$  by means of the Fourier–Motzkin elimination.*

*Proof.* STEP 1.

Let (3.1) hold, fix an orthant  $O$  and define

$$(3.2) \quad \begin{aligned} a_{ij}^- &:= \begin{cases} \underline{a}_{ij}, & \text{if } x_i x_j \geq 0 \\ \bar{a}_{ij}, & \text{if } x_i x_j < 0 \end{cases}, & a_{ij}^+ &:= \begin{cases} \bar{a}_{ij}, & \text{if } x_i x_j \geq 0 \\ \underline{a}_{ij}, & \text{if } x_i x_j < 0 \end{cases}, \\ b_i^- &:= \begin{cases} \underline{b}_i, & \text{if } x_i \geq 0 \\ \bar{b}_i, & \text{if } x_i < 0 \end{cases}, & b_i^+ &:= \begin{cases} \bar{b}_i, & \text{if } x_i \geq 0 \\ \underline{b}_i, & \text{if } x_i < 0 \end{cases}. \end{aligned}$$

Note, that the values of  $a_{ij}^-$ ,  $a_{ij}^+$ ,  $b_i^-$ ,  $b_i^+$  are constant as long as  $x$  remains in the same orthant, and that they satisfy  $a_{ij}^- = -a_{ji}^+$  and  $a_{ii}^- = a_{ii}^+ = 0$ . We first will see that (3.1) is equivalent to

$$(3.3) \quad \begin{cases} x \in S \quad \wedge \quad \exists z_{ij} \in \mathbf{R} \text{ such that} \\ \begin{cases} a_{ij}^- x_i x_j \leq z_{ij} \leq a_{ij}^+ x_i x_j, & i, j = 1, \dots, n, \quad i < j, \\ z_{ij} = -z_{ji}, & i, j = 1, \dots, n, \\ b_i^- x_i \leq \sum_{j=1}^n z_{ij} \leq b_i^+ x_i, & i = 1, \dots, n. \end{cases} \end{cases}$$

Setting  $z_{ij} := a_{ij} x_i x_j$  immediately shows “(3.1)  $\Rightarrow$  (3.3)”. In order to prove the converse we will construct  $A \in \mathbf{R}^{n \times n}$  such that  $A = -A^T \in [A]$  and  $Ax \in [b]$ . Consider a fixed index pair  $i_0, j_0$  and define  $a_{i_0 j_0}$  according to the following procedure:

Case 1:  $x_{i_0} = 0$ .

Since  $x \in S$  by (3.3), there are real numbers  $a_{i_0 j}^*$  for  $j = 1, \dots, n$  such that

$$(3.4) \quad \underline{a}_{i_0 j} \leq a_{i_0 j}^* \leq \bar{a}_{i_0 j}$$

and

$$(3.5) \quad \underline{b}_{i_0} \leq \sum_{j=1}^n a_{i_0 j}^* x_j \leq \bar{b}_{i_0}.$$

If  $x_{j_0} \neq 0$  then  $a_{i_0 j_0} := a_{i_0 j_0}^* =: -a_{j_0 i_0}$ ; if  $x_{j_0} = 0$  then  $a_{i_0 j_0} := \check{a}_{i_0 j_0}$  with  $\check{a}_{i_0 j_0}$  being the corresponding entry of the skew-symmetric midpoint matrix  $\check{A} \in [A]$ .

Case 2:  $x_{i_0} \neq 0$ .

If  $x_{j_0} \neq 0$  then  $a_{i_0 j_0} := \frac{z_{i_0 j_0}}{x_{i_0} x_{j_0}}$ ; if  $x_{j_0} = 0$  then  $a_{i_0 j_0}$  is already defined by the preceding case, when the roles of  $i_0$  and  $j_0$  are exchanged.

If one lets  $i_0$  run from 1 to  $n$  and if for each fixed  $i_0$  the second index in  $z_{i_0 j_0}$  runs from 1 to  $n$  then by the procedure above a skew-symmetric matrix  $A \in [A]$  is constructed which satisfies (3.1). Note that in Case 1 of our procedure there may occur several choices for the entries  $a_{i_0 j}^*$  such that (3.4) and (3.5) are valid. It is obvious that in this case for a fixed  $i_0$  the entries of one and the same double inequality (3.5) must be chosen for those  $j_0 = 1, \dots, n$  for which  $x_{j_0} \neq 0$ . Together with the last double inequality in (3.3) this guarantees  $\underline{b}_i \leq \sum_{j=1}^n a_{ij} x_j \leq \bar{b}_i$ .

The condition “ $x \in S$ ” in (3.3) is necessary as the example  $A := 0 \in \mathbf{R}^{1 \times 1}$ ,  $b := 1 \in \mathbf{R}$  shows. Here,  $x = 0 \in \mathbf{R}$  is clearly not in  $S \supseteq S_{skew}$ , but the remaining conditions of (3.3) are fulfilled for  $z_{11} = 0$ .

STEP 2.

By  $z_{ii} = -z_{ii}$  we obtain  $z_{ii} = 0$ . Therefore we omit  $z_{ii}$  in (3.3). We now apply the Fourier–Motzkin elimination to (3.3). We illustrate this process by eliminating  $z_{12}$ . To this end we replace  $z_{ij}$  by  $-z_{ji}$  for all  $i > j$  in the inequalities of (3.3). We rewrite these inequalities and change their order by forming three groups: The inequalities of the first group have the form  $\dots \leq z_{12}$  with  $z_{12}$ -free lefthand side, the inequalities of the second group read  $z_{12} \leq \dots$  with  $z_{12}$ -free righthand side, and the inequalities of the third group do not contain  $z_{12}$ . Since the maximum over all lefthand sides of the inequalities of the first group is less or equal than the minimum over all righthand sides of the inequalities of the second group, these inequalities are equivalent to requiring that *each* lefthand side of the first group is less or equal than *each* righthand side of the second group while keeping all inequalities of the third group. Omitting trivial inequalities, (3.3) is equivalent to

$$(3.6) \quad \left\{ \begin{array}{l} x \in S \quad \wedge \quad \exists z_{ij} \in \mathbf{R} \text{ such that} \\ \left\{ \begin{array}{l} a_{12}^- x_1 x_2 \leq b_1^+ x_1 - \sum_{j=3}^n z_{1j}, \\ a_{12}^- x_1 x_2 \leq -b_2^- x_2 + \sum_{j=3}^n z_{2j}, \\ b_1^- x_1 - \sum_{j=3}^n z_{1j} \leq a_{12}^+ x_1 x_2, \\ b_1^- x_1 - z_{11} - \sum_{j=3}^n z_{1j} \leq -b_2^- x_2 + \sum_{j=3}^n z_{2j}, \\ -b_2^+ x_2 + \sum_{j=3}^n z_{2j} \leq a_{12}^+ x_1 x_2, \\ -b_2^+ x_2 + \sum_{j=3}^n z_{2j} \leq b_1^+ x_1 - \sum_{j=3}^n z_{1j}, \\ \text{remaining (in)equalities of (3.3),} \end{array} \right. \end{array} \right.$$

where  $z_{12}$  and  $z_{21}$  do no longer occur. This process of eliminating  $z_{ij}$  can be continued until we end up with a set of final inequalities which (together with  $x \in S \cap O$ ) is equivalent to  $x \in S_{skew} \cap O$  and which contains no variable  $z_{ij}$ . This proves the theorem.  $\square$

At the end of the elimination process, there are two special inequalities for each  $i \in \{1, \dots, n\}$  which can be divided by  $x_i \neq 0$  such that no fractions occur. For example, if the first inequality of (3.6) is combined successively with the inequalities  $a_{1j}^- x_1 x_j \leq z_{1j}$  one obtains the final inequality  $\sum_{j=2}^n a_{1j}^- x_1 x_j \leq b_1^+ x_1$ . Since  $a_{11}^- = a_{11}^+ = 0$  it can be supplemented to  $\sum_{j=1}^n a_{1j}^- x_1 x_j \leq b_1^+ x_1$ , which reduces to

$$(3.7) \quad \sum_{j=1}^n a_{1j}^- x_j \leq \bar{b}_1 \quad \text{if } x_1 > 0 \quad \text{and} \quad \sum_{j=1}^n a_{1j}^- x_j \geq \underline{b}_1 \quad \text{if } x_1 < 0.$$

From the third inequality of (3.6) one obtains similarly

$$(3.8) \quad \sum_{j=1}^n a_{1j}^+ x_j \geq \underline{b}_1 \quad \text{if } x_1 > 0 \quad \text{and} \quad \sum_{j=1}^n a_{1j}^+ x_j \leq \bar{b}_1 \quad \text{if } x_1 < 0.$$

With

$$(3.9) \quad \hat{a}_{ij}^- := \begin{cases} \underline{a}_{ij}, & \text{if } x_j \geq 0 \\ \bar{a}_{ij}, & \text{if } x_j < 0 \end{cases}, \quad \hat{a}_{ij}^+ := \begin{cases} \bar{a}_{ij}, & \text{if } x_j \geq 0 \\ \underline{a}_{ij}, & \text{if } x_j < 0 \end{cases}$$

the four inequalities in (3.7) and (3.8) can be summarized to

$$\sum_{j=1}^n \hat{a}_{1j}^- x_j \leq \bar{b}_1 \quad \text{and} \quad \sum_{j=1}^n \hat{a}_{1j}^+ x_j \geq \underline{b}_1,$$

provided that  $x_1 \neq 0$ . Repeating the arguments one finally gets

$$(3.10) \quad \left. \begin{array}{l} \sum_{j=1}^n \hat{a}_{ij}^- x_j \leq \bar{b}_i, \\ \sum_{j=1}^n \hat{a}_{ij}^+ x_j \geq \underline{b}_i, \end{array} \right\} \quad i = 1, \dots, n$$

if no component of  $x$  equals 0. These inequalities are just those which characterize  $S$  and which are known as Oettli–Prager theorem (cf. [11]) which we restate as Theorem 3.4. They can either be omitted in the list of inequalities, if “ $x \in S$ ” remains there as in (3.6), or “ $x \in S$ ” can be cancelled when (3.10) is used instead. This last remark also holds if some of the components of  $x$  are zero.

We also note that the number  $n_{\#}$  of final inequalities for  $S_{skew} \cap O$  seems to be double exponential. Thus we could show that  $n_{\#}$  is roughly bounded by  $8 \cdot \left(\frac{3}{2}\right)^{2^{\kappa+1}}$  with  $\kappa := \frac{n(n+1)}{2}$ . Since the arguments are a little bit clumsy and since the proof is lengthy we will skip it.

The same technique as for  $S_{skew}$  can also be applied to construct a set of inequalities which characterize  $S_{sym}$  provided that  $[A] = [A]^T$ . In order to get the equivalence to “ $x \in S_{sym}$ ” one has to replace the equality in (3.1) by  $A = A^T$ , and one uses  $z_{ij} = z_{ji}$  in (3.3) instead of  $z_{ij} = -z_{ji}$ . Analogously to Theorem 3.2 we get

**THEOREM 3.3.** *Let  $[A] = [A]^T \in \mathbf{IR}^{n \times n}$  and let  $[b] \in \mathbf{IR}^n$ . Then for any orthant  $O \subseteq \mathbf{R}^n$  the set  $S_{sym} \cap O$  can be represented as an intersection of finitely many closed sets the boundaries of which are quadrics or hyperplanes. The inequalities characterizing these hyperplanes and quadrics can be derived from the elimination process described above, or they are of the form  $x_i = 0$ .  $\square$*

Theorem 3.3 can analogously be formulated for  $S_{per}$  since  $Ax = b \iff EAx = Eb$  whence  $S_{per}$  for  $A$  equals  $S_{sym}$  for  $EA = (EA)^T$ .

The solution set for other classes of special matrices such as Hankel or Toeplitz matrices show particularities which essentially differ from those which we have presented up to now. Thus, the inequalities need no longer remain the same in a fixed orthant and they cannot be treated by means of the particular variables  $z_{ij}$ . Work in this respect is in progress.

The inequalities (3.10) can also be obtained with the technique above if one starts with

$$(3.11) \quad x \in S$$

instead of  $x \in S_{skew}$ . The conditions corresponding to (3.3) then read

$$(3.12) \quad \exists z_{ij} \in \mathbf{R} \text{ such that } \begin{cases} \hat{a}_{ij}^- x_j \leq z_{ij} \leq \hat{a}_{ij}^+ x_j, & i, j = 1, \dots, n, \\ \underline{b}_i \leq \sum_{j=1}^n z_{ij} \leq \bar{b}_i, & i = 1, \dots, n \end{cases}$$

with  $\hat{a}_{ij}^-$ ,  $\hat{a}_{ij}^+$  from (3.9). In order to prove the implication “(3.12)  $\Rightarrow$  (3.11)” set  $a_{ij} = \frac{z_{ij}}{x_j}$  if  $x_j \neq 0$ . If  $x_j = 0$  then any element from  $[a]_{ij}$  can be used to construct a matrix  $A$  such that  $Ax \in [b]$  holds. It is easy to see that one ends up with the inequalities (3.10) if one performs the elimination process as above, starting with (3.12).

For completeness we state the result in a separate theorem.

**THEOREM 3.4.** (*Oettli–Prager Theorem, [11]*) *Let  $[A] \in \mathbf{IR}^{n \times n}$  and let  $[b] \in \mathbf{IR}^n$ . Then for any orthant  $O \subseteq \mathbf{R}^n$  the set  $S \cap O$  can be represented as the intersection of closed half spaces. These half spaces are given by*

$$(3.13) \quad \left. \begin{aligned} \sum_{j=1}^n \hat{a}_{ij}^- x_j &\leq \bar{b}_i, \\ \sum_{j=1}^n \hat{a}_{ij}^+ x_j &\geq \underline{b}_i, \end{aligned} \right\} \quad i = 1, \dots, n$$

or

$$(3.14) \quad x_i \leq 0 \quad \text{or} \quad x_i \geq 0,$$

where the inequalities in (3.14) are used to characterize the orthant  $O$  and where  $\hat{a}_{ij}^-$ ,  $\hat{a}_{ij}^+$  are defined in (3.9).  $\square$

**4. Examples.** In this section we present several examples in order to illustrate the results of Section 3. In particular, we construct the inequalities for characterizing  $S$ ,  $S_{sym}$ ,  $S_{per}$  and  $S_{skew}$ .

In our first example we consider  $2 \times 2$  interval matrices.

**EXAMPLE 4.1.**

- a) Let  $[A] \in \mathbf{IR}^{2 \times 2}$ ,  $[b] \in \mathbf{IR}^2$ . Then  $S$  is characterized according to (3.13) by the inequalities

$$(4.1) \quad \begin{cases} \hat{a}_{11}^- x_1 + \hat{a}_{12}^- x_2 &\leq \bar{b}_1, & \hat{a}_{11}^+ x_1 + \hat{a}_{12}^+ x_2 &\geq \underline{b}_1, \\ \hat{a}_{21}^- x_1 + \hat{a}_{22}^- x_2 &\leq \bar{b}_2, & \hat{a}_{21}^+ x_1 + \hat{a}_{22}^+ x_2 &\geq \underline{b}_2, \end{cases}$$

with the coefficients according to (3.9).

- b) Let  $[A] = [A]^T$  hold. The symmetric solution set  $S_{sym}$  is described by the four inequalities in (4.1) supplemented by the two inequalities

$$(4.2) \quad \begin{cases} b_1^- x_1 - b_2^+ x_2 - a_{11}^+ x_1^2 + a_{22}^- x_2^2 &\leq 0, \\ -b_1^+ x_1 + b_2^- x_2 + a_{11}^- x_1^2 - a_{22}^+ x_2^2 &\leq 0 \end{cases}$$

with the coefficients from (3.2). These inequalities show that the boundary of  $S_{sym}$  can be curvilinear already in the  $2 \times 2$  case.

- c) Let  $E[A] = (E[A])^T$  hold. The persymmetric solution set  $S_{per}$  is described by the four inequalities in (4.1) supplemented by the two inequalities in (4.2) if one redefines  $a_{ij}^\pm$ ,  $b_i^\pm$  appropriately.

- d) Let  $[A] = -[A]^T$  hold with  $[a]_{ii} = 0$  for  $i = 1, 2$ . The skew-symmetric solution set  $S_{skew}$  is given by the four inequalities in (4.1) with  $\hat{a}_{ii}^- = \hat{a}_{ii}^+ = 0$ , in addition to the two inequalities

$$(4.3) \quad b_1^- x_1 \leq -b_2^- x_2, \quad -b_2^+ x_2 \leq b_1^+ x_1,$$

which follow directly from (3.6) taking into account  $z_{11} = z_{22} = 0$ . The skew-symmetric solution set in  $\mathbf{R}^2$  is apparently bounded by a polygon, i. e., its boundary is formed by straight lines. Taking into account  $\hat{a}_{ii}^- = \hat{a}_{ii}^+ = 0$  one sees immediately from (4.1) that the solution set  $S$  is an interval vector. This is not always the case for  $S_{skew}$ . For example, choose  $[b] := (1, 1)^T$  and  $[a]_{12} := [0.25, 1]$ . Then any skew-symmetric element  $A$  of  $[A]$  can be written in the form

$$A = \alpha \begin{pmatrix} 0 & 1 \\ -1 & 0 \end{pmatrix} = -\alpha^2 A^{-1} \quad \text{with } 0.25 \leq \alpha \leq 1.$$

Hence  $S_{skew} = \{\beta(-1, 1)^T \mid 1 \leq \beta \leq 4\}$ , i. e.,  $S_{skew}$  is the straight line in the plane between the points  $(-1, 1)$  and  $(-4, 4)$ . The corresponding solution set  $S$ , however, is given by

$$S = \{(-\beta, \gamma)^T \mid 1 \leq \beta, \gamma \leq 4\} = ([-4, -1], [1, 4])^T.$$

□

In our second example we consider  $3 \times 3$  tridiagonal interval matrices.

EXAMPLE 4.2.

- a) Let  $[A] \in \mathbf{IR}^{3 \times 3}$  with  $[a]_{13} = [a]_{31} := 0$ , and let  $[b] \in \mathbf{R}^3$ . Then  $S$  is characterized by the inequalities

$$(4.4) \quad \left\{ \begin{array}{ll} \hat{a}_{11}^- x_1 + \hat{a}_{12}^- x_2 \leq \bar{b}_1, & \hat{a}_{11}^+ x_1 + \hat{a}_{12}^+ x_2 \geq \underline{b}_1, \\ \hat{a}_{21}^- x_1 + \hat{a}_{22}^- x_2 + \hat{a}_{23}^- x_3 \leq \bar{b}_2, & \hat{a}_{21}^+ x_1 + \hat{a}_{22}^+ x_2 + \hat{a}_{23}^+ x_3 \geq \underline{b}_2, \\ \hat{a}_{32}^- x_2 + \hat{a}_{33}^- x_3 \leq \bar{b}_3, & \hat{a}_{32}^+ x_2 + \hat{a}_{33}^+ x_3 \geq \underline{b}_3 \end{array} \right.$$

where the coefficients are again given by (3.9).

- b) For tridiagonal  $3 \times 3$  matrices  $[A] = [A]^T$  the symmetric solution set  $S_{sym}$  is characterized by the six inequalities in (4.4) and by the four additional inequalities

$$(4.5) \quad \left\{ \begin{array}{l} +b_1^- x_1 - b_2^+ x_2 - a_{11}^+ x_1^2 + a_{22}^- x_2^2 + a_{23}^- x_2 x_3 \leq 0, \\ +b_1^- x_1 - b_2^+ x_2 + b_3^- x_3 - a_{11}^+ x_1^2 + a_{22}^- x_2^2 - a_{33}^+ x_3^2 \leq 0, \\ +b_1^- x_1 - (+b_2^+ - b_2^-) x_2 - a_{11}^+ x_1^2 - a_{12}^+ x_1 x_2 - (+a_{22}^+ - a_{22}^-) x_2^2 \leq 0, \\ +b_2^- x_2 - b_3^+ x_3 - a_{12}^+ x_1 x_2 - a_{22}^+ x_2^2 + a_{33}^- x_3^2 \leq 0 \end{array} \right.$$

together with their four counterparts, which one gets by replacing each minus sign by a plus sign, and vice versa (also in the superscripts). The coefficients of (4.5) are defined in (3.2). Note that the information of the third inequality in (4.5) is contained in that of the first row of (4.4) if  $[b]_2$  and  $[a]_{22}$  are point intervals.

Without proof we mention that the number of inequalities for  $S_{sym}$  increases to 44 for a dense  $3 \times 3$  system.

- c) The skew-symmetric solution set  $S_{skew}$  is characterized by (4.4) with  $\hat{a}_{ii}^- = \hat{a}_{ii}^+ = 0$  for  $i = 1, 2, 3$ , and by the inequalities

$$(4.6) \quad \left\{ \begin{array}{l} -b_1^+ x_1 - b_2^+ x_2 + a_{23}^- x_2 x_3 \leq 0, \\ +b_1^- x_1 + b_2^- x_2 + b_3^- x_3 \leq 0, \\ +b_1^- x_1 - (+b_2^+ - b_2^-) x_2 - a_{12}^+ x_1 x_2 \leq 0, \\ -b_2^+ x_2 - b_3^+ x_3 - a_{12}^+ x_1 x_2 \leq 0 \end{array} \right.$$

together with their four counterparts, which are defined analogously as for  $S_{sym}$ . The inequalities in (4.6) look similar to those in (4.5) when taking into account  $[a]_{ii} = 0$  for  $i = 1, 2, 3$ . Again the third inequality in (4.6) equals the first one in (4.4) if  $[b_2]$  is a point interval. Note also that according to Section 1 each skew-symmetric matrix from  $\mathbf{R}^{3 \times 3}$  is singular!  $\square$

In our third example we describe  $S$  and  $S_{skew}$  in two different ways, a direct way (feasible since there is only one nontrivial pair of intervals) and a second way where we will apply the results of Example 4.2.

EXAMPLE 4.3. Let

$$[A] := \begin{pmatrix} 0 & 1 & 0 \\ -1 & 0 & [0.5, 1] \\ 0 & [-1, -0.5] & 0 \end{pmatrix}, \quad [b] := \begin{pmatrix} [0, 2] \\ 0 \\ -1 \end{pmatrix}.$$

Then  $[A] = -[A]^T$  with  $[a]_{ii} = 0$ ,  $i = 1, 2, 3$ . Each  $A \in [A]$ ,  $b \in [b]$  can be represented as

$$A = \begin{pmatrix} 0 & 1 & 0 \\ -1 & 0 & \alpha \\ 0 & -\beta & 0 \end{pmatrix}, \quad b = \begin{pmatrix} \gamma \\ 0 \\ -1 \end{pmatrix}$$

with  $\alpha, \beta \in [0.5, 1]$ ,  $\gamma \in [0, 2]$ . The linear system  $Ax = b$  then reads

$$(4.7) \quad x_2 = \gamma,$$

$$(4.8) \quad -x_1 + \alpha x_3 = 0,$$

$$(4.9) \quad -\beta x_2 = -1.$$

- a) We first want to describe the solution set  $S$ . The equations (4.7) and (4.8) show that  $x_2 \geq 0$  and  $\text{sign}(x_1 x_3) \geq 0$ . This means that only the first orthant  $O_1$  and the sixth orthant  $O_6$  can contain elements of  $S$ , where  $O_1$  is characterized by  $x_i \geq 0$ ,  $i = 1, 2, 3$ , and where  $O_6$  is given by  $x_1 \leq 0$ ,  $x_2 \geq 0$ ,  $x_3 \leq 0$ . By the first and the third equation the system (4.7) – (4.9) is solvable if and only if  $\beta\gamma = 1$ . This is possible for any  $\beta \in [0.5, 1]$  since  $\gamma = \beta^{-1} \in [1, 2] \subseteq [0, 2]$ . The solution can be rewritten as

$$(4.10) \quad x_1 = \alpha x_3, \quad x_2 = \beta^{-1}, \quad x_3 \in \mathbf{R}.$$

For each fixed  $\alpha, \beta \in [0.5, 1]$  these equations represent, of course, a straight line which lies in the plane  $x_2 = \beta^{-1} \in [1, 2]$  and which crosses the  $x_2$ -axis at  $(0, \beta^{-1}, 0)$ . For each fixed  $\beta \in [0.5, 1]$  one thus gets a (double) sector in  $O_1 \cup O_6$  which is bounded by the straight lines  $x_1 = 0.5x_3$  and  $x_1 = x_3$  while  $x_2 = \beta^{-1}$ . Varying  $\beta$  results in two wedges the cutting edges of which have length 1 and meet at the  $x_2$ -axis from  $(0, 1, 0)$  to  $(0, 2, 0)$ .

- b) In order to characterize  $S_{skew}$  let  $\alpha = \beta$ . From (4.10) we obtain then  $x_1 x_2 = x_3$  with  $x_2 \in [1, 2]$ , i. e.,  $S_{skew}$  is the intersection of  $S$  with the hyperbolical paraboloid  $x_3 = x_1 x_2$  which transforms to  $y_3 = y_1^2 - y_2^2$  via  $x_1 = y_1 + y_2$ ,  $x_2 = y_1 - y_2$ ,  $x_3 = y_3$ . In particular, the boundary of  $S_{skew}$  is curvilinear. The following Figure 1 shows  $S \cap O_1$  and  $S_{skew} \cap O_1$ . The intersection  $S \cap O_6$

and  $S_{skew} \cap O_6$  are obtained by rotating the two sets around the  $x_2$ -axis by an amount of  $180^\circ$  degrees.

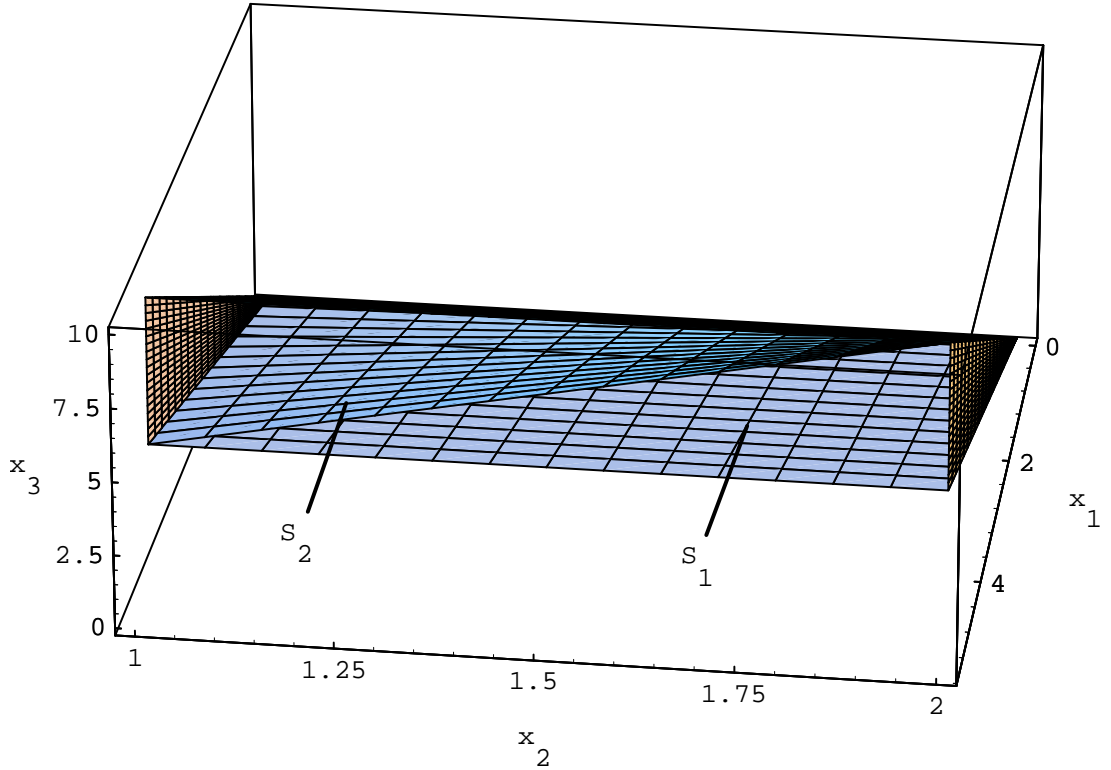

**Fig. 1** The shape of the solution sets  $S_1 := S \cap O_1$ ,  $S_2 := S_{skew} \cap O_1$  in Example 4.3.

- c) We now want to describe  $S$  and  $S_{skew}$  in a second way, namely by the inequalities resulting from (4.4) and (4.6). For simplicity we already use  $S \subseteq O_1 \cup O_6$  which yields  $a_{23}^- = 0.5 = -a_{32}^+$ ,  $a_{23}^+ = 1 = -a_{32}^-$ . The inequalities (4.4) can then be written in the form

$$(4.11) \quad 0 \leq x_2 \leq 2,$$

$$(4.12) \quad 0.5x_3 \leq x_1 \leq x_3,$$

$$(4.13) \quad 1 \leq x_2 \leq 2,$$

if  $(x_1, x_2, x_3) \in O_1$ . In  $O_6$  the inequality (4.12) has to be replaced by  $x_3 \leq x_1 \leq 0.5x_3$ . Since (4.13) is more restrictive than (4.11) we can omit (4.11). Thus  $S$  is characterized by (4.12) and (4.13).

The inequalities (4.6) and their counterparts yield to

$$(4.14) \quad b_1^- x_1 \leq x_2 x_3 \leq 2b_1^+ x_1,$$

$$(4.15) \quad b_1^- x_1 \leq x_3 \leq b_1^+ x_1,$$

$$(4.16) \quad b_1^- x_1 \leq x_1 x_2 \leq b_1^+ x_1,$$

$$(4.17) \quad x_3 = x_1 x_2$$

in  $O_1$ ; in  $O_6$  the inequality (4.14) must be exchanged by  $2b_1^- x_1 \leq x_2 x_3 \leq b_1^+ x_1$ . Dividing (4.16) by  $x_1$  implies (4.11). Hence (4.16) can be omitted. Since (4.15) is identical with (4.16) if (4.17) is used, we can skip (4.15), too. Replacing  $x_3$  in (4.14) by (4.17) and dividing by  $x_1$  yields to  $0 = \underline{b}_1 \leq x_2^2 \leq 2\bar{b}_1 \leq 4$  which again is fulfilled if (4.11) holds. Therefore, the inequalities for  $S_{skew}$  reduce in  $O_1$  to

$$\begin{aligned} 1 &\leq x_2 \leq 2, \\ x_1 &\leq x_3 \leq 2x_1, \\ x_3 &= x_1 x_2, \end{aligned}$$

which is equivalent to (4.10) when taking into account  $\alpha, \beta \in [0.5, 1]$ . The same holds in  $O_6$  if the second double inequality is replaced by  $2x_1 \leq x_3 \leq x_1$ .  $\square$

In our last example we consider a  $2 \times 2$  interval matrix  $[A]$  which satisfies  $[A] = [A]^T$ .

EXAMPLE 4.4. Let

$$[A] := \begin{pmatrix} 1 & [0, 1] \\ [0, 1] & [-4, -1] \end{pmatrix}, \quad [b] := \begin{pmatrix} [0, 2] \\ [0, 2] \end{pmatrix}.$$

Then  $[A] = [A]^T$  with

$$A = \begin{pmatrix} 1 & \alpha \\ \beta & -\gamma \end{pmatrix} \in [A] \implies A^{-1} = \frac{1}{\gamma + \alpha\beta} \begin{pmatrix} \gamma & \alpha \\ \beta & -1 \end{pmatrix}$$

with  $\alpha, \beta \in [0, 1]$ ,  $\gamma \in [1, 4]$ . Since  $\underline{b} \geq 0$  the first component of  $A^{-1}b$  is nonnegative for all  $b \in [b]$ . Therefore,  $S$  is completely contained in the union  $O_1 \cup O_4$  of the first and the fourth quadrant.

We first consider  $S \cap O_1$ . According to (4.1) we get the inequalities

$$(4.18) \quad x_1 \leq 2, \quad x_2 \geq -0.5, \quad x_2 \geq -x_1, \quad x_1 \geq x_2.$$

This means that  $S \cap O_1$  is the triangle with the corners  $(0, 0)$ ,  $(2, 0)$  and  $(2, 2)$ .

The corresponding inequalities for  $S \cap O_4$  are given by

$$(4.19) \quad x_1 \geq 0, \quad x_2 \geq -2, \quad x_2 \leq 2 - x_1, \quad x_2 \leq 0.25 x_1.$$

They describe a quadrangle with the corners  $(0, 0)$ ,  $(0, -2)$ ,  $(4, -2)$  and  $(2, 0)$ .

In order to describe  $S_{sym} \cap O_1$  we need the inequalities (4.18) and the two inequalities from (4.2) which can be transform to

$$(4.20) \quad 4x_1^2 + (4x_2 + 1)^2 \geq 1 \quad (x_1 - 1)^2 + x_2^2 \leq 1.$$

The first inequality of (4.20) describes an ellipse and its exterior. Since the ellipse lies completely in the lower half plane the first inequality of (4.20) is therefore no restriction for  $S_{sym} \cap O_1$ . The second inequality describes a closed disc  $D_1$  with center  $(1, 0)$  and radius 1. The boundary of the intersection with  $S \cap O_1$  is formed by the straight line from  $(0, 0)$  to  $(1, 1)$ , the part of the circle  $\partial D_1$  from  $(1, 1)$  to  $(2, 0)$  and the part of the  $x_1$  axis from  $(2, 0)$  back to  $(0, 0)$ .

The inequalities in (4.19) together with the two inequalities

$$(4.21) \quad x_1^2 + 4x_2^2 \geq 0 \quad (x_1 - 1)^2 + (x_2 + 1)^2 \leq 2.$$

characterize  $S_{sym} \cap O_4$ . The first inequality in (4.21) is always true. The second inequality describes a disc  $D_2$  with center  $(1, -1)$  and radius  $\sqrt{2}$ . The boundary of its intersection with  $S \cap O_4$  is formed by the straight lines from  $(0, 0)$  to  $(0, -2)$ , from  $(0, -2)$  to  $(2, -2)$  and from  $(2, 0)$  to  $(0, 0)$ , and by the part of the circle  $\partial D_2$  from  $(2, -2)$  to  $(2, 0)$ . The situation is illustrated by Figure 2.  $\square$

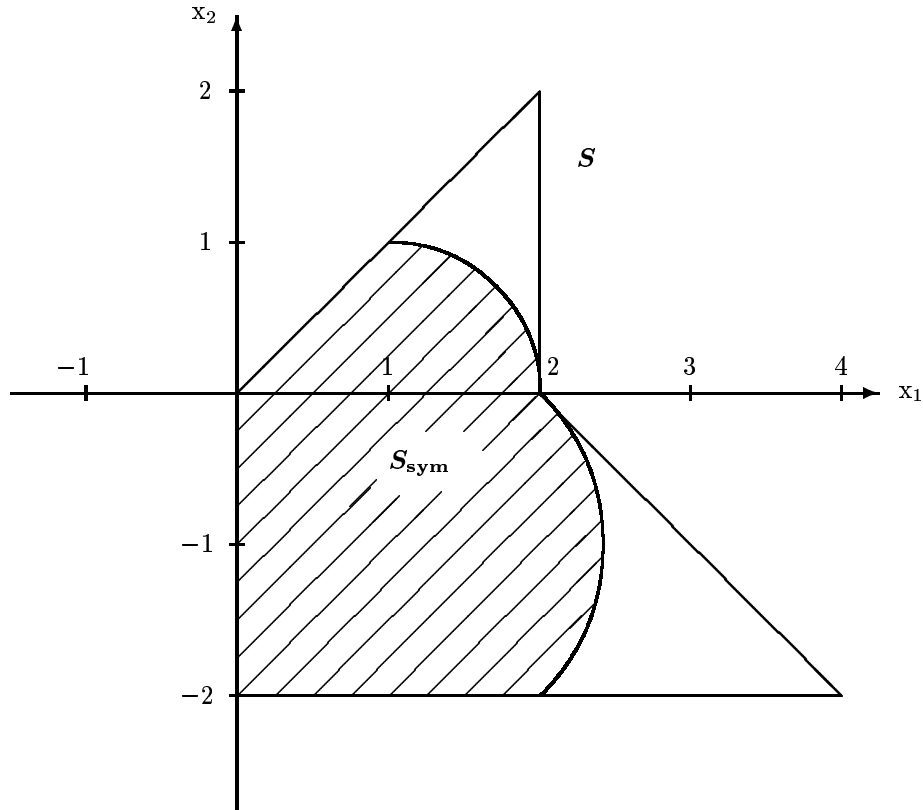

**Fig. 2** The shape of the solution sets  $S$ ,  $S_{sym}$  in Example 4.4.

**Acknowledgement.** We thank both referees for their valuable suggestions and remarks which improved this paper.

## REFERENCES

- [1] G. ALEFELD AND J. HERZBERGER, *Introduction to Interval Computations*, Academic Press, New York, 1983.
- [2] G. ALEFELD, V. KREINOVICH, AND G. MAYER, *The Shape of the Symmetric Solution Set*, in Applications of Interval Computations, R. B. Kearfott and V. Kreinovich, eds., Kluwer, Boston, MA, 1995, pp. 61–79.
- [3] G. ALEFELD, V. KREINOVICH, AND G. MAYER, *Symmetric Linear Systems with Perturbed Input Data*, in Numerical Methods and Error Bounds, G. Alefeld and J. Herzberger, eds., Akademie Verlag, Berlin, 1996, pp. 16–22.
- [4] G. ALEFELD AND G. MAYER, *On the Symmetric and Unsymmetric Solution Set of Interval Systems*, SIAM J. Matrix Anal. Appl. 16 (1995), pp. 1223–1240.
- [5] H. BEECK, *Über Struktur und Abschätzungen der Lösungsmenge von linearen Gleichungssystemen mit Intervalkoeffizienten*, Computing 10 (1972), pp. 231–244.
- [6] G. H. GOLUB AND CH. F. VAN LOAN, *Matrix Computations*, The Johns Hopkins University Press, Baltimore, Maryland, 1983.
- [7] D. J. HARTFIEL, *Concerning the Solution Set of  $Ax = b$  where  $P \leq A \leq Q$  and  $p \leq b \leq q$* , Numer. Math. 35 (1980), pp. 355–359.
- [8] C. JANSSON, *Rigorous Sensitivity Analysis for Real Symmetric Matrices with Uncertain Data*, in Computer Arithmetic, Scientific Computation and Mathematical Modelling, E. Kaucher, S. M. Markov, and G. Mayer, eds., Baltzer, Basel, 1991, pp. 293–316.
- [9] C. JANSSON, *Interval Linear Systems with Symmetric Matrices, Skew-Symmetric Matrices and Dependencies in the Right Hand Side*, Computing 46 (1991), pp. 265–274.
- [10] A. NEUMAIER, *Interval Methods for Systems of Equations*, Cambridge University Press, Cambridge, 1990.
- [11] W. OETTLI AND W. PRAGER, *Compatibility of Approximate Solution of Linear Equations with Given Error Bounds for Coefficients and Right-hand Sides*, Numer. Math. 6 (1964), pp. 405–409.
- [12] J. ROHN, *Interval Linear Systems* Freiburger Intervall-Berichte 84/7 (1984), pp. 33–58.
- [13] S. M. RUMP, *Verification Methods for Dense and Sparse Systems of Equations*, in Topics in Validated Computations, J. Herzberger, ed., Elsevier, Amsterdam, 1994, pp. 63–135.
- [14] A. SCHRIJVER, *Theory of Linear and Integer Programming*, Wiley, New York, 1986.